

RSSD: Defend against Ransomware with Hardware-Isolated Network-Storage Codesign and Post-Attack Analysis*

Benjamin Reidys
UIUC

Peng Liu
Pennsylvania State University

Jian Huang
UIUC

ABSTRACT

Encryption ransomware has become a notorious malware. It encrypts user data on storage devices like solid-state drives (SSDs) and demands a ransom to restore data for users. To bypass existing defenses, ransomware would keep evolving and performing new attack models. For instance, we identify and validate three new attacks, including (1) garbage-collection (GC) attack that exploits storage capacity and keeps writing data to trigger GC and force SSDs to release the retained data; (2) timing attack that intentionally slows down the pace of encrypting data and hides its I/O patterns to escape existing defense; (3) trimming attack that utilizes the trim command available in SSDs to physically erase data.

To enhance the robustness of SSDs against these attacks, we propose RSSD, a ransomware-aware SSD. It redesigns the flash management of SSDs for enabling the hardware-assisted logging, which can conservatively retain older versions of user data and received storage operations in time order with low overhead. It also employs hardware-isolated NVMe over Ethernet to expand local storage capacity by transparently offloading the logs to remote cloud/servers in a secure manner. RSSD enables post-attack analysis by building a trusted evidence chain of storage operations to assist the investigation of ransomware attacks. We develop RSSD with a real-world SSD FPGA board. Our evaluation shows that RSSD can defend against new and future ransomware attacks, while introducing negligible performance overhead.

1 BACKGROUND AND MOTIVATION

Although secure storage systems have been developed for decades, encryption ransomware imposes new challenges and has become one of the biggest cybersecurity threats. It stealthily encrypts user data and demands ransom from users to restore their data. Recent studies report that ransomware attack could happen every 11 seconds, the victims include governments, schools, hospitals, police departments, and personal computers. Each attack requests an average of \$8,100 and costs nearly \$300,000 in server downtime. These ongoing ransomware outbreaks and global damage reflect the fact that the current security design of storage systems falls short of defending against encryption ransomware.

To defend against ransomware attacks, software-based approaches, such as intrusion detection and data backup have been proposed. Unfortunately, software-based solutions suffer from four major limitations. First, since software-based solutions are not hardware isolated from malicious processes, they can be compromised by ransomware. Particularly, attackers could obtain OS kernel privilege and terminate software-based backup systems. Moreover, even though the ransomware detection succeeds, some files have been encrypted and victims still have to pay to get their data back. Second, attackers can hide in the system long before deploying their ransomware. Third, ransomware can overwrite data backups with encrypted versions. Finally, software-based solutions usually lack the capability of trusted post-attack analysis, which impedes the progress of recovering from an attack.

Table 1: Comparison with state-of-the-art approaches. The 6th column represents Data Recovery (○: Unrecoverable, ◐: Partially Recoverable, ●: Recoverable). The 7th column represents Post-Attack Analysis or Storage Forensics.

	Related	Defend New Attacks			Recovery	Forensics
		GC	Timing	Trimming		
Software	Unveil [2]	×	×	×	○	×
	CryptoDrop	×	×	×	○	×
	CloudBackup	×	✓	×	◐	×
	ShieldFS	×	×	×	◐	×
	JFS	×	×	×	○	×
Hardware	FlashGuard [1]	✓	×	×	◐	×
	TimeSSD	✓	×	×	◐	×
	SSDInsider	×	×	×	◐	×
	RBlocker	×	×	×	◐	×
	RSSD	✓	✓	✓	●	✓

To defend against ransomware attacks, recent work exploited the intrinsic flash properties to detect ransomware attacks and restore victim data. However, they have three major limitations. First, they were mainly developed to defend against existing encryption ransomware which assumed the underlying storage devices perform like conventional HDDs. As SSDs have been widely used, ransomware will evolve and update their attack models. Therefore, we must anticipate and proactively prevent new ransomware attacks. Second, due to the limited storage capacity, we can only retain the stale data for a limited time. This will significantly affect storage performance, especially for data-intensive workloads. Even worse, ransomware could take advantage of limited storage capacity to initiate new attacks. Third, most defenses do not support post-attack or forensic analysis, which will miss the opportunity to learn new attack models. This slows down the post-attack investigation and limits their ability to adapt to evolving malware.

2 THREAT MODEL

As discussed in §1, malicious users could elevate their privilege to run as administrators and disable/destroy the software-based data backup solutions. We do not assume the OS is trusted, instead, we trust the SSD firmware. We believe this is a realistic threat model for two reasons. First, the SSD firmware is located within the storage controller, underneath the generic block interface. It is hardware-isolated from higher-level malicious processes. Second, SSD firmware has a much smaller trusted computing base (TCB) than the OS kernel, making it typically less vulnerable to malware attacks. Once the firmware is flushed into the SSD controller, commodity SSDs will not allow firmware modifications without authentication, which guarantees the implementation integrity.

3 DESIGN AND IMPLEMENTATION

Ransomware 2.0: As SSDs have become prevalent in a vast majority of computing platforms because of their increased performance and decreased cost, we believe new ransomware attack models with awareness of flash properties will happen, creating a new generation of security threats that we call Ransomware 2.0. These new attacks will both encrypt user data and defeat existing data protection schemes.

In this paper, we present three new ransomware attacks that can circumvent existing SSD-based protections: (1) *GC attack*, in which ransomware exploits the limited storage capacity of SSDs and

*This work has been published at ASPLOS'22 [3]

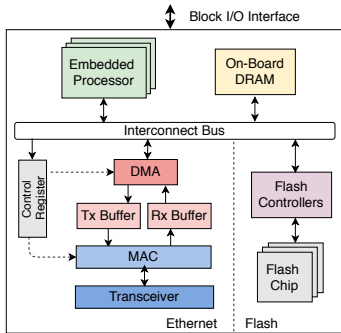

Figure 1: Architecture of RSSD

dumps data to occupy the available storage space and force SSDs to release retained data. (2) *Timing attack*, in which ransomware intentionally slows down the pace of encrypting data and hides its I/O patterns behind user operations. (3) *Trimming attack*, in which ransomware utilizes the *trim* command in commodity SSDs to erase flash pages and remove the original copies of encrypted data.

It is not easy to defend against these new attacks, since each of them will generate new I/O patterns that can bypass existing detection and defense mechanisms. For instance, existing detection approaches worked by identifying the repeating I/O patterns. The timing attack can bypass it by intentionally lowering the attack frequency and imitating regular storage I/O patterns. The GC attack can invalidate existing data recovery schemes by forcing the SSD to conduct GC operations and erase the retained data. And the trimming attack enables ransomware to speed up the removal of the original data copies that have been encrypted.

From our analysis of Ransomware 2.0, we identify zero data loss recovery and trusted post-attack analysis as critical for solutions against evolutions of ransomware. To implement these features, we develop a ransomware-aware SSD named RSSD, shown in Figure 1. **Zero data loss recovery:** RSSD enables zero data loss recovery by conservatively retaining all stale data. Thus, RSSD guarantees that all data that may be locked by ransomware is retained. However, this can incur significant performance overhead. Therefore, RSSD proposes a hardware-isolated NVMe over Ethernet (NVMe-oE) to transfer the retained pages in a compressed and encrypted format to remote cloud or storage servers in time order, while keeping the valid pages locally for performance. This enables RSSD to expand its local storage capacity in a secure and transparent manner.

To mitigate the trimming attack, we rethink the hardware support for the *trim* command in SSDs. The feature of using *trim* commands to directly notify SSDs to garbage collect flash pages, would be attractive to ransomware, since it can bypass existing defenses. Instead of disabling the *trim* command, RSSD enhances it. Specifically, upon receiving *trim* commands, RSSD will allocate new flash pages and remap the addresses touched by the *trim* command to these new pages. RSSD will retain the trimmed data, therefore, it can still restore the victim data upon trimming attack.

Trusted post-attack analysis: To enable efficient and trusted post-attack analysis, we extend RSSD and retain the log of storage operations in the SSD. Thus, RSSD has the capability of reproducing the storage operations in the original order they were issued. As the logging approach is hardware isolated, RSSD can build a trusted evidence chain for post-attack or forensic analysis. Since most of the retained logs and data will be transferred remotely, RSSD enables the offloading of ransomware detection and analysis to remote servers. Therefore, we can detect ransomware more efficiently and accurately by utilizing the powerful computing resources and the

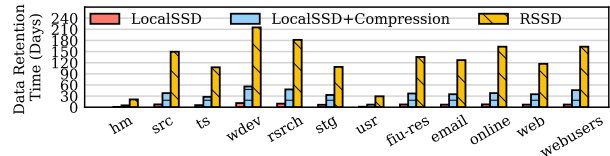

Figure 2: Data retention time in RSSD.

flexibility of deploying various detection algorithms. RSSD also allows fast reconstruction of evidence chains by backtracking storage operations with our hardware-assisted logging.

Key contributions: We list the key contributions of this work.

- We conduct an empirical study of more than a hundred ransomware cases and confirm that the lack of efficient data recovery and post-attack analysis is the major weakness of modern storage systems and ransomware defense solutions.
- We present a new understanding of Ransomware 2.0, discuss and validate three new ransomware attacks that include GC attack, timing attack, and trimming attack.
- We develop a new SSD that uses the hardware-isolated NVMe-oE to safely extend the retention time for the hardware-assisted logging, and enable the offloading of ransomware detection and analysis to the remote cloud/servers.
- We rethink the storage architecture support for the *trim* command in SSDs and enhance its security by enabling the retention of trimmed data with hardware-assisted logging.
- We present a hardware-isolated post-attack analysis approach that can efficiently build a trusted evidence chain of storage operations that lead up to an attack.

Implementation of RSSD: We implement RSSD with a Cosmos+OpenSSD FPGA board, a cloud storage service Amazon S3, and local storage servers. We use various storage benchmarks and I/O traces, and ransomware samples collected from VirusTotal [4]. Our evaluation shows that RSSD can retain all obsolete data across the SSD and remote cloud/servers, with minimal storage cost, and negligible impact on the local storage performance and device lifetime. We replay multiple ransomware attacks on RSSD, and show that RSSD can restore the data encrypted by ransomware, and correctly reconstruct the original sequence of I/O events that lead to the attacks in a short time.

Performance of RSSD: Our evaluation shows that (1) RSSD can retain the stale data for a much longer time than state-of-the-art approaches, over 200 days in our evaluation (see Figure 2); (2) It has less than 1% negative impact on storage performance and minimal impact on device lifetime; (3) It performs fast data recovery after attacks; (4) It enables efficient post-attack analysis by building a trusted chain of I/O operations (see [3] for the full evaluation).

REFERENCES

- [1] Jian Huang, Jun Xu, Xinyu Xing, Peng Liu, and Moinuddin K. Qureshi. 2017. FlashGuard: Leveraging Intrinsic Flash Properties to Defend Against Encryption Ransomware. In *Proceedings of the 24th ACM Conference on Computer and Communications Security (CCS'17)*. Dallas, TX.
- [2] Amin Kharaz, Sajjad Arshad, Collin Mulliner, William Robertson, and Engin Kirda. 2016. UNVEIL: A Large-Scale, Automated Approach to Detecting Ransomware. In *25th USENIX Security Symposium (USENIX Security 16)*. USENIX Association, Austin, TX, 757–772.
- [3] Benjamin Reidys, Peng Liu, and Jian Huang. 2022. RSSD: Defend against Ransomware with Hardware-Isolated Network-Storage Codesign and Post-Attack Analysis. In *Proceedings of the 27th ACM International Conference on Architectural Support for Programming Languages and Operating Systems (ASPLOS'22)* (Lausanne, Switzerland).
- [4] VirusTotal - Free Online Virus, Malware and URL Scanner. 2016. <https://www.virustotal.com/>.